

Volvo Construction Equipment  
Building Tomorrow



# A60H

Volvo Articulated Haulers 55 t 639 hp



# A passion for performance

At Volvo Construction Equipment, we're not just coming along for the ride. Developing products and services that raise productivity – we are confident we can lower costs and increase profits for industry experts. Part of the Volvo Group, we are passionate about innovative solutions to help you work smarter – not harder.

## Helping you to do more

Doing more with less is a trademark of Volvo Construction Equipment. High productivity has long been married to low energy consumption, ease of use and durability. When it comes to lowering life-cycle costs, Volvo is in a class of its own.

## Designed to fit your needs

There is a lot riding on creating solutions that are suited to the particular needs of different industry applications. Innovation often involves high technology – but it doesn't always have to. Some of our best ideas have been simple, based on a clear and deep understanding of our customers' working lives.



## You learn a lot in 180 years

Over the years, Volvo has advanced solutions that have revolutionized the use of construction equipment. No other name speaks Safety louder than Volvo. Protecting operators, those around them and minimizing our environmental impact are traditional values that continue to shape our product design philosophy.

## We're on your side

We back the Volvo brand with the best people. Volvo is truly a global enterprise, one that is on standby to support customers quickly and efficiently – wherever they are.

## We have a passion for performance.



Volvo Trucks



Renault Trucks



Mack Trucks



UD Trucks



Volvo Buses



Volvo Construction Equipment



Volvo Penta



Volvo Financial Services

# Pure uptime

Get continuous production with this bigger, durable and superior machine – always available and ready to work. Count on superb reliability thanks to the machine's robust design, easy service access and outstanding Volvo dealer network. Guarantee pure uptime.

## Guaranteed durability

Increase your uptime using heavy-duty front and rear frames, hitch and wet disk brakes. Volvo proven durability and the support of extensive warranty options means you never need to worry about getting the job done. Strength and durability are hallmarks of the Volvo articulated hauler.



## Fifty years strong

Fifty years and fifty tonnes later, Volvo is the world's leading manufacturer of articulated haulers. We invented the concept and have been developing and building these machines for over 50 years – it has come a long way from its original 10 tonne articulated hauler. With proven success over the years, the machines include innovative technology and the renowned Volvo engine.



## Service access

With industry-leading access, servicing your machine is quick and easy. The front grill swings down, opening a service platform with anti-slip steps. The electric hood opens to 90 degrees, allowing full and safe access to the engine compartment.



## Volvo dealer network

The exclusive Volvo dealer network is there to support you whenever you need it. Volvo offers a number of services, local knowledge and global experience, including telematics machine monitoring – CareTrack™ and MATRIS™ – as well as superb parts availability.





# UPTIME

Get ready to work with the all new A60H. Designed for heavy hauling in severe off-road operation, the machine's long service life, quality, reliability and durability is everything you expect from a Volvo. Hauling is easier and more efficient.



# PROFITABILITY

Reduce cost per tonne with a higher payload. The state-of-the-art design allows for more capacity while improving fuel efficiency so you can move more for less.

# Move more, make more

Increase your business's profitability by moving more for less. Industry-leading fuel efficiency, innovative technology and vital operational data tools help to optimize production and control your maintenance costs, maximising your return on investment.

## Fuel efficiency guarantee

The A60H, powered by the world-renowned Volvo engine, delivers excellent fuel efficiency without compromising on power or performance. With guaranteed fuel efficiency, this machine will increase your profitability and improve your return on investment.



## Maximise your investment

Meet your targets faster with the A60H. Increase your earnings with a higher payload and greater productivity for lower cost per tonne.



## Control your maintenance costs

The range of Customer Support Agreements offer preventive maintenance, total repairs and a number of uptime services. Volvo uses the latest technology to monitor machine operation and status, giving you advice to increase your profitability. By having a Customer Support Agreement you are in control of your service costs.



## Operational data

Receive valuable data to improve onsite efficiency and save costs. With intelligent systems from Volvo such as MATRIS™, CareTrack™ and the On Board Weighing system, you will optimize your production and minimise your operational costs.



# Bigger and bolder

Achieve astounding productivity with the A60H. This machine is the ultimate hauler, featuring 100% off-road performance, proven Volvo technology and impressive payload – contributing to sustainable operations, year after year.

## Articulated hauler concept

Go where others can't. The A60H embodies the full articulated hauler concept and provides total versatility so you can access the entire jobsite and climb steeper gradients. Work in all seasons, terrains and applications using tailored machine configurations and tires, optimized for this 60 tonne machine.



## The best articulated hauler

The ground-breaking A60H is the best articulated hauler on the market and the latest innovation from Volvo. With matched drivetrain, automatic drive combinations including 100% differential locks, all-terrain bogie, hydro-mechanical steering and active suspension, this machine is unbeatable.



## Comfort at speed

A60H is fitted with active hydraulic front suspension – permitting high hauling speeds in tough conditions. This optimizes operator comfort and stability during travel. Move more material in a shorter time for unmatched productivity.



## Load optimization

The On Board Weighing System guarantees the optimal load every cycle. This maximizes production, boosts fuel efficiency and reduces machine wear in all site conditions and operations.







# PRODUCTIVITY

The A60H can move more tonnes per hour and give a 100% in all conditions. The largest articulated hauler on the market has a bigger payload for your application, delivering up to 40% more productivity.

# Simply the best and the biggest

## PROFITABILITY

The state-of-the-art design allows for more capacity while improving fuel efficiency so you can move more for less.

### Fifty years strong

Fifty years and fifty tonnes later, Volvo is the world's leading manufacturer of articulated haulers.

### Guaranteed durability

Increase your uptime using heavy-duty front and rear frames, hitch and wet disk brakes.

### The best articulated hauler

The ground-breaking A60H is the best articulated hauler on the market and the latest innovation from Volvo.

### Maximize your investment

Meet your targets faster. Increase your earnings with higher payload and greater productivity for lower cost per tonne.

## PRODUCTIVITY

The A60H can move more tonnes per hour and give a 100% in all conditions.



### Load optimization

The On Board Weighing System guarantees the optimal load every cycle.

### OPERATOR'S CHOICE

Its comfortable cab and ease of operation, even in adverse conditions, makes operators choose this machine.

### Fuel efficiency guarantee

The A60H is powered by the world-renowned Volvo engine delivers excellent fuel efficiency without compromising on power or performance.

### Service access

With industry-leading access, servicing your machine is quick and easy.

### UPTIME

Designed for heavy hauling in severe off-road operation, its long service life, quality, reliability and durability is everything you expect from a Volvo.

### Articulated hauler concept

Go where others can't. The machine embodies the full articulated hauler concept and provides total versatility.





# OPERATOR'S CHOICE

When many other machines are onsite, most operators prefer the Volvo. Its comfortable cab and ease of operation, even in adverse conditions, makes operators choose this machine.

# The ultimate operating environment

The A60H is the number one operator's choice because of its industry-leading spacious cab and comfortable work environment. Its superior comfort, control, ease of operation and safety appeals to operators, maintaining productivity all day, every day.

## Total operator control

Stay in control at all times. The dump support system, dynamic Volvo engine brake and load and dump brake, all help the operator to control the machine for extra productivity and safety.



## Operator comfort

Feel comfortable and spend more time in the A60H. The centrally positioned operator, superior steering, excellent suspension, low noise levels, climate control, space and visibility, reduce operator fatigue for more effective operations.



## Ease of operation

The ergonomic, comfortable controls are easy to understand and suit all operators, combined with automatic functions for increased ease of operation.



## Safety

A number of safety features such as superior visibility and efficient lighting help to keep the operator and people working around the machine safe in the most demanding working environments – whether it's the operator, trainers, mechanics or site workers.

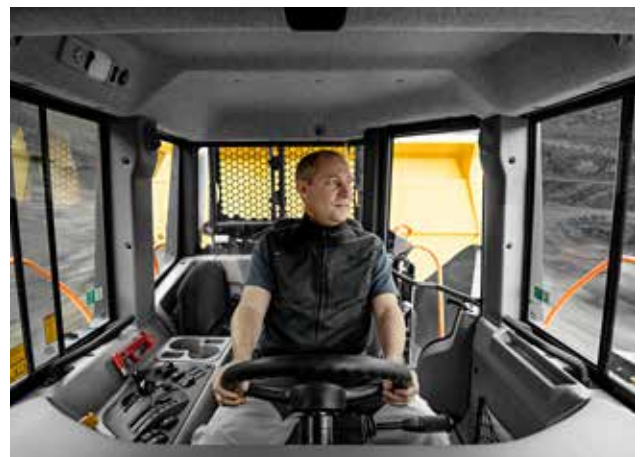

# Volvo A60H in detail

## Engine

V-ACT, 16 liter, 6-cylinder straight VGT (Variable Geometry Turbocharged) diesel engine with 4 valves per cylinder, overhead camshaft and electronically controlled unit injectors. It has wet replaceable cylinder liners and replaceable valve guides and valve seats. The engine has cooled EGR (Exhaust Gas Recirculation) and exhaust after treatment with EAT-Muffler (Exhaust After treatment) including DOC (Diesel Oxidation Catalyst), DPF (Diesel Particulate Filter) and SCR (Selective Catalytic Reduction) with an electronically controlled UDS (Urea Dosing System). After treatment system features passive DPF regeneration with an AHI (After treatment Hydro carbon Injection) device as back up.

Engine model	Volvo	D16J
Max power - SAE J1995 Gross	kW	470
	hp	639
at engine speed	r/min	1 800
Flywheel power - ISO 9249, SAE J1349 Net	kW	467
	hp	635
at engine speed	r/min	1 800
Max torque - SAE J1995 Gross	Nm	2 960
Max torque - ISO 9249, SAE J1349 Net	Nm	2 942
at engine speed	r/min	1 050
Displacement	l	16.1

## Electrical system

All cables, sockets and pins are identified. Cables are enclosed in plastic conduits and secured to main frame. Halogen lights. Prewired for options. Connectors meet IP67 standard for water-proofing as necessary.

Voltage	V	24
Battery	V	2x12
Battery capacity	Ah	2x225
Alternator	kW/A	2.264/80
Starter motor	kW	9

## Drivetrain

Torque converter with built-in lock-up function.

Transmission: Fully automatic Allison planetary transmission with 6 forward gears and 2 reverse gears. Internal torsional damper in the torque converter.

Dropbox: Volvo-developed, in-line design with high ground clearance and 100% longitudinal "dog clutch" type differential lock.

Axles: Heavy duty, purpose built Volvo design with fully floating axle shafts, planetary type hub reductions and 100% dog clutch type diff-lock.

Automatic traction control system (ATC).

Torque converter		1.85:1
Transmission	Volvo	6630 ORS
Dropbox	Volvo	IL3 ATC
Axles	Volvo	AHW80

## Brake system

Fully hydraulic, wet multiple disc brakes with enclosed, forced oil-cooled multiple discs on all wheels. Two circuit brake system. Complies with ISO 3450 at total machine weight.

Circuit division: One circuit for front axle and one for bogie axles.

Parking brake: Spring-applied disc brake on the propeller shaft, designed to hold a loaded machine on a grade of up to 18%. When the parking brake is applied, the longitudinal differential is locked.

Retarder: Service brake retarder function and Volvo Engine Brake (VEB).

## Steering System

Hydro-mechanical articulated steering, self compensating design.

Two double-acting steering cylinders.

Steering angle: 3,4 steering wheel turns lock-to-lock,  $\pm 45^\circ$ .

Steering system, including secondary steering fulfil ISO 5010.

## Chassis

Frames: box type, heavy duty. High strength steel, robot welded.

Rotating hitch: 100% maintenance free, fully sealed, with permanently greased tapered roller bearings.

## Cab

Mounted on rubber pads. Ergonomically designed. Easy entry and exit. Wide angle forward view.  
Operator centrally positioned above the front axle. Adjustable operators seat with retractable seat belt.  
Tilt/telescopic steering wheel. Ergonomically positioned controls. Filtered air. Optional climate control system.  
Operator communication system: Contronics.  
Large color display, user-friendly and easy-to-understand information, all vital machine functions are constantly monitored.  
Instructor seat with seat belt.  
Safety: ROPS/FOPS standards approved according to ISO3471, SAE J1040 / ISO3449, SAE J231.

Sound level in cab (ISO 6396) - LpA	dB(A)	72
External sound level (ISO 6395) - LwA	dB(A)	113
Internal sound level with sound kit: 70 dB(A)		
External sound level with sound kit: 111 dB(A).		

## Suspension

Front suspension: Unique, full hydraulic, with automatic leveling and stabilizer.  
Rear suspension: 100% maintenance free. Straddle mounted bogie beam. Independent wheel movement via a 3-point mounting system.

Hydraulic cylinders (struts), front/rear		2/0
Accumulators, oil-nitrogen, high pressure, front		2
Levelling sensors		2

## Hydraulic system

Pumps: Five variable displacement piston pumps driven by the flywheel PTO.  
One ground-dependent piston pump for secondary steering mounted on the dropbox.  
Two return oil filters with magnetic cores provide effective oil filtration.

System max working pressure	MPa	28
-----------------------------	-----	----

## Dumping System

Patented Load and Dump Brake.  
Dumping Cylinders: two single stage double acting cylinders.

Tipping angle	°	70
Tipping time with load	s	13
Lowering time	s	10

## Body

### Plate thickness

Front	mm	8
Sides	mm	14
Bottom	mm	16
Chute	mm	16

### Material

HB400 steel

Yield strength	N/mm <sup>2</sup>	1 000
Tensile strength	N/mm <sup>2</sup>	1 250

## Load Capacity

### Standard Body

Load capacity	kg	55 000
Body, struck	m <sup>3</sup>	25.8
Body, heaped 2:1	m <sup>3</sup>	33.6

### With overhung tailgate

Body, struck	m <sup>3</sup>	26.5
Body, heaped 2:1	m <sup>3</sup>	35.1

# Specifications

## REFILL CAPACITIES

Crankcase	l	55
Fuel tank	l	750
Cooling system	l	75
Brake cooling system	l	131
Transmission	l	58
Dropbox	l	12
Axles, front/bogie	l	74/147
Hydraulic tank	l	198
DEF/AdBlue®	l	60

®registered trademark of the Verband der Automobilindustrie e.V. (VDA)

## SPEED

Forward		
1	km/h	6.5
2	km/h	9.7
3	km/h	12.9
4	km/h	19.2
5	km/h	25.9
6	km/h	54.9
Reverse		
1	km/h	5
2	km/h	7.5

## OPERATING WEIGHT UNLOADED

Tires		33.25R29
Front	kg	22 750
Rear	kg	21 000
Total	kg	43 750
Payload	kg	55 000

Operating weight includes all fluids and operator

## TOTAL WEIGHT

Tires		33.25R29
Front	kg	28 900
Rear	kg	69 850
Total	kg	98 750

## GROUND PRESSURE

Tires		33.25R29
Unloaded		
Front	kPa	125
Rear	kPa	58
Loaded		
Front	kPa	159
Rear	kPa	193

## Excavator PASS MATCHING

	EC480	EC750
	Number of passes	
A60H	11	7

Well matched, 4-6 buckets.
Excavator under capacity, 7 buckets or more.
Excavator undersized for optimum match.

## Wheel loader PASS MATCHING

	L220	L250	L350
	Number of passes		
A60H	6	5	4

Well matched, 2-4 buckets.
Loader under capacity, 5 buckets or more.
Loader undersized for optimum match, reach might be an issue.



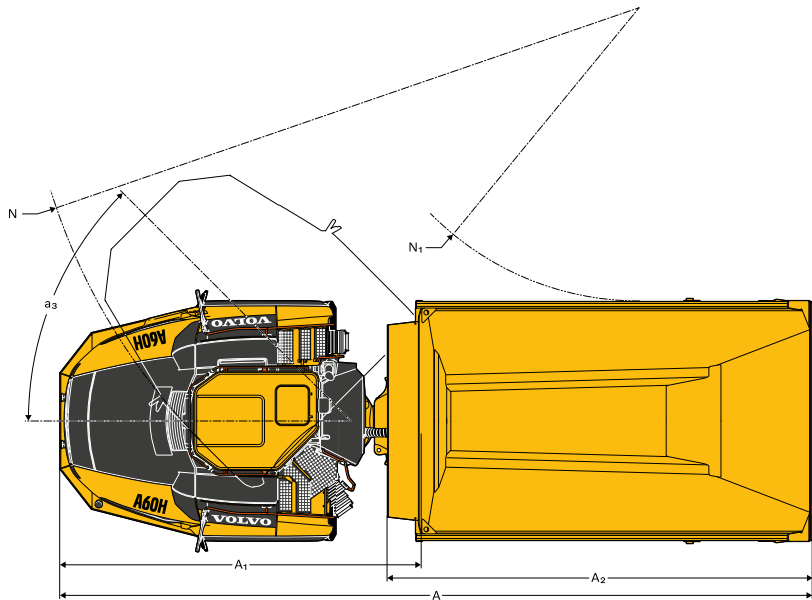
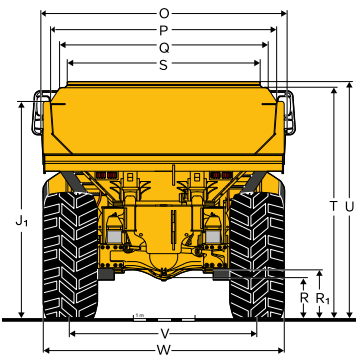
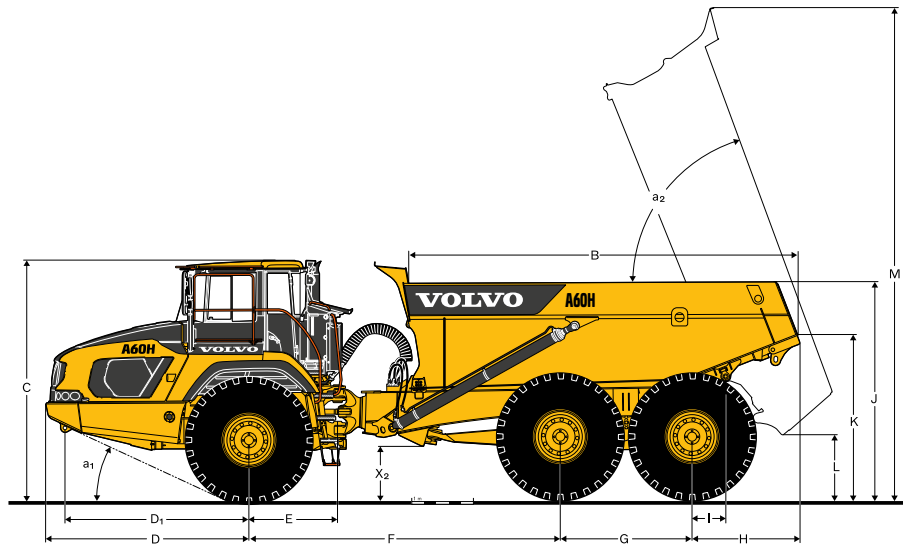
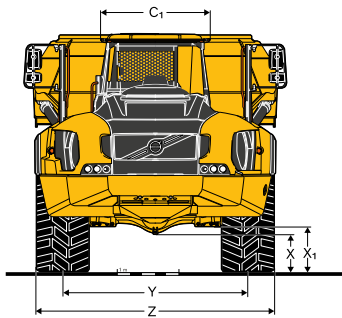

#### DIMENSIONS

Pos	Unit	A60H
A	mm	12 225
A <sub>1</sub>	mm	5 872
A <sub>2</sub>	mm	6 900
B	mm	6 310
C	mm	3 852
C <sub>1</sub>	mm	1 772
D	mm	3 293
D <sub>1</sub>	mm	2 986
E	mm	1 440
F	mm	5 050
G	mm	2 140
H	mm	1 743
I	mm	541
J	mm	3 510
K	mm	2 658
L	mm	1 030
M	mm	7 960
N	mm	10 014
N <sub>1</sub>	mm	4 761

#### DIMENSIONS

Pos	Unit	A60H
O	mm	3 989
P	mm	3 673
Q	mm	3 370
R	mm	677
R <sub>1</sub>	mm	778
S	mm	3 126
T	mm	3 734
U	mm	3 833
V	mm	3 010
W	mm	3 884
X	mm	601
X <sub>1</sub>	mm	727
X <sub>2</sub>	mm	845
Y	mm	3 010
Z	mm	3 884
a <sub>1</sub>	°	24.9
a <sub>2</sub>	°	70
a <sub>3</sub>	°	45

A60H: Unloaded machine with 33.25R29 tires.

# Equipment

## STANDARD EQUIPMENT

### Engine

Direct injected, electronically controlled, turbocharged, intercooled  
 Grouped oil filters, for ease of change  
 Preheater for easier cold starts  
 VEB (exhaust retarder EPG + compression brake)

### Tires

33.25R29  
 800/80R29

### Drivetrain

6x4 and 6x6 automatically engaged drive modes  
 Dog clutch type 100% diff-locks in all axles  
 Full automatic transmission  
 Two-stage dropbox with longitudinal diff-lock  
 Torque converter with automatic lock-up

### Electrical system

80 A alternator  
 Battery disconnect switch  
 Extra 24 V socket for lunch cooler

#### Lights:

Back-up light  
 Brake lights  
 Cab lighting  
 Direction indicators  
 Headlights  
 Instrument lighting  
 Parking lights  
 Rear lights

### Brake System

Hill assist  
 Load & Dump Brake  
 Retarder pedal  
 Parking brake on propeller shaft  
 Two circuit, fully hydraulic, wet discs on all axles

### Body

Body prepared for exhaust heating and optional equipment  
 On board weighing (OBW)

### Safety

Anti-slip steps and platforms  
 Dump body lock  
 Handrails on steps and platforms  
 Hazard lights  
 Horn  
 Protective grill for cab rear window  
 Rear-view mirrors  
 Retractable 3-inch safety belt  
 ROPS/ FOPS protected Care Cab  
 Secondary steering  
 Steering joint lock  
 Windshield washers  
 Windshield wipers with interval function  
 Dump support system

## STANDARD EQUIPMENT

### Comfort

ACC control panel  
 Ashtray  
 Cab heater with filtered fresh air and defroster  
 Can holder /storage tray  
 Cigarette lighter  
 Instructor seat with seat belt  
 Overhead console for radio  
 Sliding window  
 Space for lunch cooler  
 Storage box  
 Sun visor  
 Tilt/telescopic steering wheel  
 Tinted glass

### Operator information interface

Gauges:  
 Brake pressure  
 Fuel  
 Speedometer  
 Tachometer  
 Wet disc brakes cooling oil temperature

### Warning lights grouped and easy to read

Central warning (3 levels) for all vital functions

### Central positioned information display

Automatic pre-start checks  
 Clock  
 Hour meter  
 Operational information, easy-to-navigate menu  
 Troubleshooting diagnostics

### Exterior

Front mudguard wideners and rear mudflaps

### Service and Maintenance

Electrical engine hood and belly plate  
 Drainage hose  
 Machine Tracking Information System MATRIS  
 Service platform integrated in the front grill  
 Tool box

## OPTIONAL EQUIPMENT

### Engine

Air filter, heavy duty, EON  
 Engine heater, 240 V  
 Engine heater, diesel (Eberspächer)  
 Engine auto shutdown  
 Engine shutdown timer  
 External emergency engine stop  
 High engine idle speed

---

**OPTIONAL EQUIPMENT**

---

**Electrical system**

- Headlights, LED
- Warning beacon, LED
- Working lights, LED
- Entrance light
- Seat belt indicator, external
- Anti-theft system (pin code)
- Rear view camera
- Reverse alarm
- CAN-BUS interface, extra

**Cab**

- Noise reduction kit (fulfils 2000/14/EC)
- Anchorage, operator's manual
- Cab heating/ventilation timer
- Cable kit, for cab heater
- HEPA cab air filter
- Bluetooth radio kit
- Rear view mirrors, adjustable, el.heated
- Seat belt XXL, non-retractable
- Sun blinds, side windows
- Universal key
- Air suspended, heated, fully adjustable seat
- Armrest for operator seat
- Headrest for operator seat
- Air blow gun

---

**OPTIONAL EQUIPMENT**

---

**Body**

- Body exhaust heating
- Front spillguard, extra
- Side extension, light material
- Tailgate, overhung, wire-operated
- Wear plates

**Safety**

- Fire suppression system
- Warning triangle
- First aid kit and fire extinguisher
- Fire extinguisher
- Wheel chocks

**Service and Maintenance**

- Lube system, standard machine
- Tool kit

**Other**

- Siberian kit -40°C
- Arctic oil kit
- CareTrack
- Fast fuelling system
- Jump start connector, NATO -type

---

**SELECTION OF VOLVO OPTIONAL EQUIPMENT**

---

**LED lighting****Tailgate****Fast fuelling****Volvo fire suppression system**

Not all products are available in all markets. Under our policy of continuous improvement, we reserve the right to change specifications and design without prior notice. The illustrations do not necessarily show the standard version of the machine.

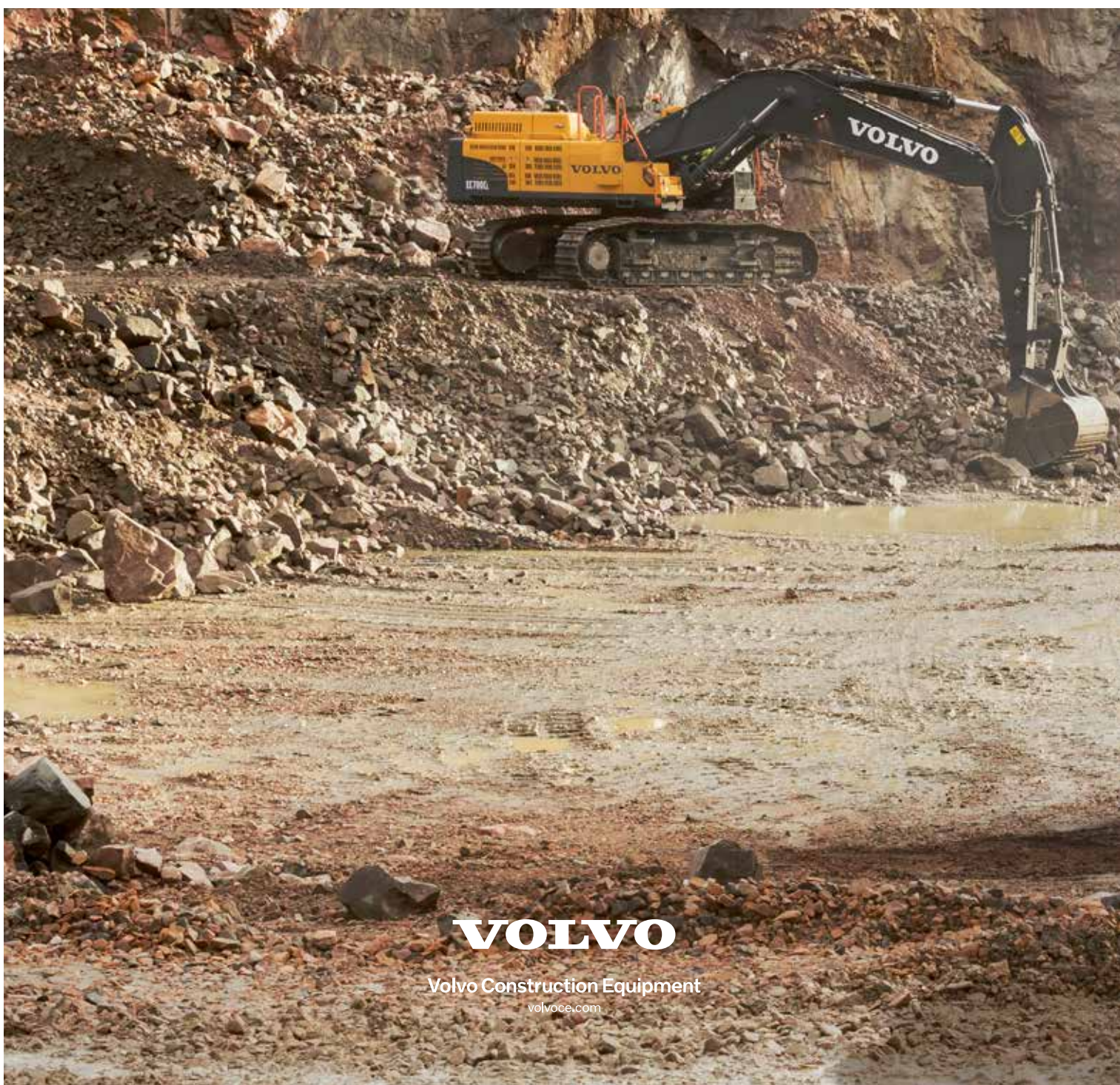

**VOLVO**

Volvo Construction Equipment  
volvoce.com